

DAVINCI DESIGN CORP

CONVERTING SOLUTIONS



FRESH IDEAS

DAVINCI DESIGN CORP

ROLLMASTER 1100

This completely microprocessor controlled Slitter Winder was specifically designed to handle very thin film such as, Thermal Transfer, Hot Stamp, Holographic Media ...



FRESH IDEAS

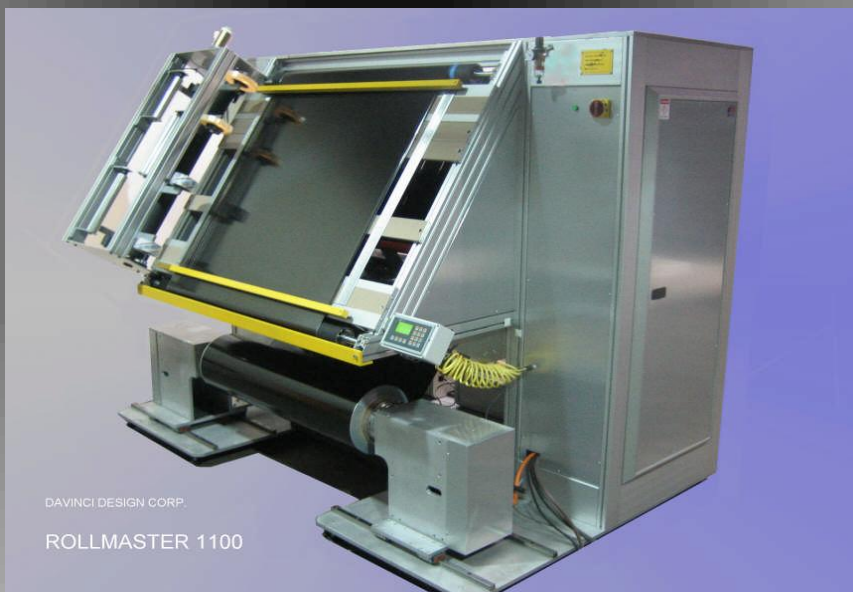

Sophistication has not compromised ease of use; although many different design features and programmable functions have been combined into this state of the art slitting machine, operator friendliness is definitely one of its strong suites.

The **RM 1100** is a very flexible tool, which we are sure, will greatly enhance your production capabilities

DAVINCI DESIGN CORP

ROLLMASTER 1100 FEATURES

Slanted Leader table with pneumatic clamping bars and vacuum supported cutting bars. Table is fully adjustable to any leader configuration. Nip driven, shaftless leader unwind for 3 piece leader with tape holders for top and bottom feed.

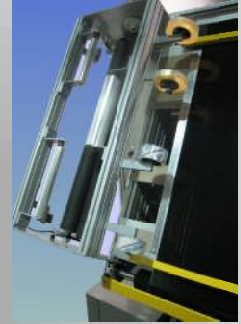

Closed loop dancer controlled, driven shaftless unwind stand, with 6" air chucks. On the fly electrical side shift controlled from either operator panel. Unwind mounted on linear bearing tracks.

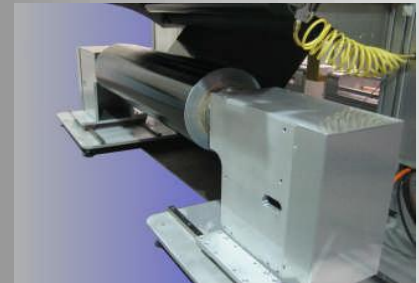

Pneumatically operated razor slitting system. Quick change magnetic blade holders for 20mm minimum Slit width. Dual turrets with air rewind shafts and bearing type rewind shaft supports. Air operated linear surface roller assemblies with antistatic discharge bars.



Touch screen operator interface for control of all machine functions. Internal closed loop rewind tension control with Taper tension. Recipe utility for job storage.



FRESH IDEAS

DAVINCI DESIGN CORP

ROLLMASTER 1100 FEATURES

Servo motor torque controlled trim winder.
Adjustable speed and travel traversing feature.
Operator adjustable rewind tension.
Quick release rewind shafts.



Core box for rewind shaft loading / unloading.
Infinitely adjustable down to 25 mm ribbon width.
Will accept 1/2" to 1 1/4" shaft size.
Air gun for shaft inflation.
Table top mount.

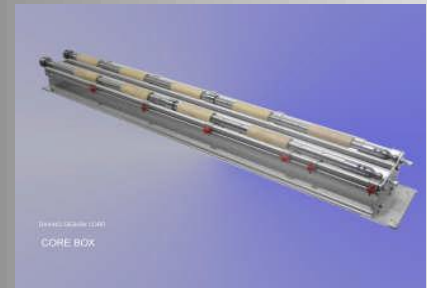

Quick change razor blade holder. Allows fast and accurate positioning for quick job changes.
Magnetic razor blade holding feature for ultra fast blade changes.



Pneumatically operated rewind core notching device.
Can cut 4 x 8 mm notch for 1" and 1/2" cores.
Single or dual notch at 90 or 180 degrees.



FRESH IDEAS

DAVINCI DESIGN CORP

ROLLMASTER 1100 WEB PATH

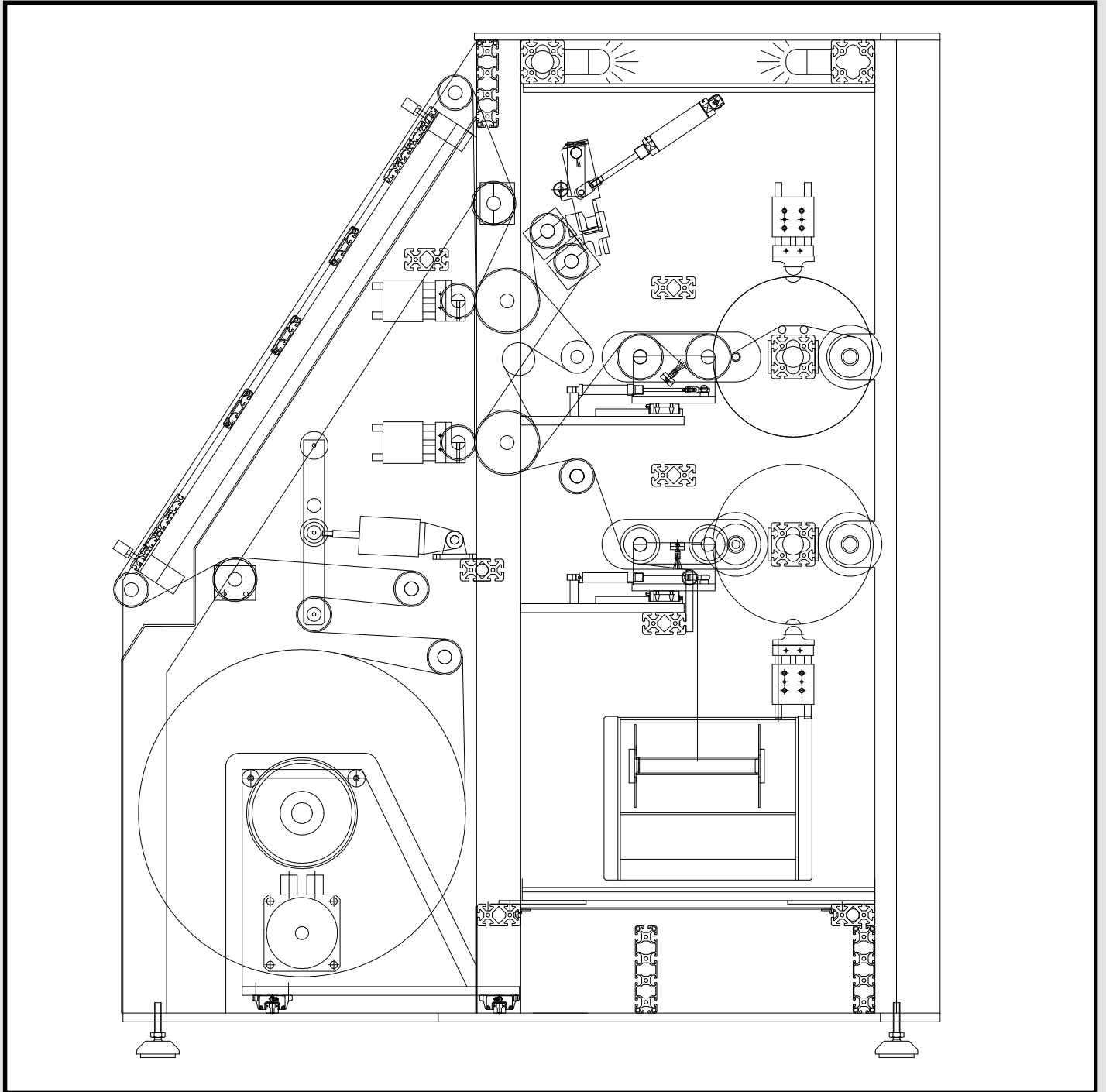

FRESH IDEAS

DAVINCI DESIGN CORP

ROLLMASTER 1100 EXTENT OF DELIVERY

INCLUDED IN BASE PRICE OF MACHINE:

- Main structure complete.
- Closed loop controlled shaftless unwind stand with electrical side shift feature.
- Leader table with air operated clamping bars, two vacuum supported cutting bars and three film support bars.
- Motorized, nip driven leader unwind with three shaftless unwinds and five tape dispensers for top or bottom feed.
- Servo driven main drive assembly with two nipped pull rollers.
- One bow roller and all necessary idler rollers.
- Razor in air slitting station with 10 pieces quick change magnetic blade holders.
- Two air operated surface roller assemblies with integrated antistatic discharge bars.
- Servo driven dual turret assemblies
- Four 1 inch air rewind shafts with bearing type shaft supports.
- Two traversing trim winders with servo tension control.
- Touch screen operator panel.

FRESH IDEAS

DAVINCI DESIGN CORP

ROLLMASTER 1100 TECHNICAL SPECIFICATIONS

- Max. running speed 300 M/min.
- Maxi. Web width 1100 mm
- Max. jumbo roll diameter 610 mm
- Unwind chuck diameter 152.4 mm
- Max. rewind diameter 125 mm
- Min. rewind shaft diameter 12.7mm
- Min. slitting width (smaller on request) 20 mm
- Winding technique locked core
- Air supply 6 bar
- Control voltage 24 VDC
- Power supply 400 VAC 3 phase
- Foot print L x W x H 2.4 x 1.5 x 1.8 M

FRESH IDEAS

DAVINCI DESIGN CORP

ROLLMASTER 1100 TERMS AND CONDITIONS

PAYMENT: 50% down with order
45% before shipment
5% upon completion of installation

DELIVERY: Standard delivery is 18 weeks. Exact delivery Time is based on workload at time of order.

- All prices are quoted ex works without packaging.
- Without written agreement, customer is responsible for insurance during shipment.
- Equipment remains the sole property of Davinci Design Corp. until paid in full.
- Customer is responsible for sufficient test materials to be delivered to seller upon his request.
- DDC reserves the right for minor design changes without customer approval.

WARRANTY: Davinci Design Corp. warranty covers the period of one year from the time of commissioning (2100hrs) according to the US Manufacturers Associations standard conditions of supply (supplied on request)

FRESH IDEAS

DAVINCI DESIGN CORP

ROLLMASTER 1100 SERVICE RATES

HOURLY RATES:

| | | |
|---|-----|----------|
| Regular working time | USD | 65.-/hr |
| Overtime (in excess of 9 hours per day) | USD | 100.-/hr |
| Sundays | USD | 150.-/hr |
| Travel time | USD | 45.-/hr |

TRAVEL EXPENSES:

All travel expenses are charged at cost.

Meal charges are billed at \$ 50.- per day within the continental USA, Canada.

Meal expenses in other locations are charged at cost.

NOTE:

Travel time is not considered when calculating overtime.

Travel time is calculated door to door.

Daily travel from and to living accommodations are considered regular working time.

FRESH IDEAS

DAVINCI DESIGN CORP.

TERMS AND CONDITIONS rev. 1.1.2007 # TC01

1. ENTIRE CONTRACT. The terms and conditions contained herein and other terms and conditions stated in seller's proposal or specifications attached hereto, shall constitute the complete agreement between the seller and the purchaser and shall supersede all prior understandings, transactions and communications whether oral or written, with respect to the matters referred to herein and form the complete contract between the seller and the purchaser. Seller is not bound by any terms and conditions sale unless agreed to in writing by Seller's authorized representatives at its home office. No modification, alterations, waiver, or amendment of the terms and conditions of sale herein, whether by conditions in Purchaser's order forms or in Purchaser's written and signed by Seller's authorized representatives at Seller's home office. The failure of Seller to object to any provision in conflict herewith, whether contained on the Purchaser's purchase order or otherwise, shall not be construed as a waiver of the provisions hereof or as an acceptance of the Purchaser's terms.

2. ACCEPTANCE and TRANSPORTATION. All products and equipment which are the subject matter hereof (Goods") will be shipped ex works. Seller's point of shipment. Upon Purchaser's receipt of shipment, Purchaser shall immediately inspect the Goods. Unless Purchaser provides Seller with written notice describing with particularity the nature of any defects in the goods of the amount of any shortage claimed within thirty (30) calendar days after receipt of shipment, the Goods shall be deemed accepted by Purchaser. Unless special shipping instructions are received from the Purchaser substantially before the shipment date, Seller will use its discretion as to the best means of shipment and routing. Seller shall not be held responsible for loss or damages or excess cost resulting from the means of shipment or routing used or for any other losses or damages arising while in transit, and the Purchaser agrees to make nay claim there for directly against the carrier. The cost of premium transportation or other methods of transportation specified by Purchaser (including, but not limited to, airfreight and overnight delivery service) will be borne by Purchaser.

3. TITLE and RISK of LOSS. Title to Goods sold and risk of loss of such Goods shall pass to Purchaser at the ex works shipping point.

4. WARRANTY. Seller warrants, goods manufactured by it will be free of defects in material and workmanship for one (1) year, following the date of shipment. If any of the goods are found by purchaser to be defective, such good will, at seller's option, be replaced or repaired at seller's cost. The parties hereto expressly agree that seller's liability (whether under the theories of breach of contract or warranty, negligence , or strict liability) and purchaser's sole and exclusive remedy against seller shall be the repair or replacement of goods found by seller to be defective, or at sellers option, to refunding of the purchase price of such goods or parts thereof. The exclusive remedy shall not be deemed to have failed, of it's essential purpose, so long as the seller is willing and able to repair or replace defective goods in the prescribed manner. The foregoing warranty is in lieu of all other warranties, expressed or implied including those of merchantability or fitness for any purpose not expressly set forth herein. No affirmation of seller, by works of action, other then set forth in this section, shall constitute a warranty. Seller's warranty those not apply to any goods which have been subjected to misuse, mishandling, misapplication, neglect (including but not limited to use of unauthorized parts or attachments), or adjustment or repair performed by anyone other than seller or one of seller's authorized agents. Any claim by purchaser with reference to the goods sold hereunder shall be deemed waived by the purchaser, if unless submitted in writing to seller within the earlier (i) thirty days following

the date purchaser discovered or by reasonable inspection should have discovered, nay claimed breach of the foregoing warranty, or (ii) twelve (12) month following the date of shipment. Any cause of action for breach of the foregoing warranty shall be brought within one year from the date the alleged breach was discovered or should have been discovered, whichever comes first.

5. DISCLAIMER OF CONSEQUENTIAL DAMAGES. In no event shall seller be liable for incidental or consequential damages arising out of or in connection with this agreement, including, without limitation, breach of any obligation, or warranty imposed on seller hereunder or in connection herewith. Consequential damages for purpose hereof shall include without limitation, loss of use, income or profit, or losses sustained as a result of injury to any person, or loss of or damage to any property (including, without limitation, property handled or processed through the use of the goods), or damages or losses sustained as a result of work stoppage. Purchaser shall indemnify seller against all liability, cost or expense, which may be sustained by purchaser on account of any such loss, damage or injury.

6. TAXES. The price herein does not include any applicable sales, use, excise or any such similar taxes which Seller may be required to pay or collect from the Purchaser. Any such taxes will be added to each invoice unless the Purchaser has furnished Seller with an appropriate tax exemption certificate acceptable to Seller. Seller will further invoice the Purchaser for, and Purchaser will pay to Seller any other tax or charge hereafter imposed by any governmental authority upon any part of the Goods described herein or the production, sales, transportation or delivery thereof, or upon any other feature of this transaction.

7. TERMINATION, CANCELLATION and CHANGES. Orders cannot be terminated, canceled or modified, or shipment deferred after acceptance of Purchaser's order by Seller, except with Seller's written consent. In the event of any termination or cancellation, the Purchaser shall pay to Seller within thirty days of such termination or cancellation all contract cost and other expenses incurred by Seller prior to receipt of the request for termination or cancellation, including, but not limited to, engineering expense and all commitments to its suppliers, subcontractors and other (the "Termination Costs"), plus an amount equal to 15% of the Termination Costs to cover general and administrative expenses, plus an amount equal to 10% of the Termination Costs. In the event of any modification or change, Seller shall be entitled to revise its price and delivery schedules to reflect such change and , among other things, provide for profit on work in process and contract value of products or parts completed and ready for shipment.

8. PATENTS and COPYRIGHT. Except as provided below, Seller shall not be liable for damages arising from infringement or alleged infringement of patents or copyrights. Except wney Purchaser supplies the specifications for the Goods, if as a result of an infringement or alleged infringement, Purchaser is enjoined from using any of the Goods purchased pursuant to this Agreement, Seller, at its option, shall promptly either (i) secure termination of the injunction and procure for Purchaser the right of use of such Goods without any obligation or liability, or (ii) replace said Goods with non infringing materials or modify same to become non infringing, all at Seller's expense and to Purchaser's reasonable satisfaction, or (iii) remove said Goods to Purchaser. This shall be purchaser's exclusive remedy against seller with respect to patent or copyright infringement. The sale of Goods hereunder does not convey any license or copyright under any proprietary or patent rights of any manufacturer. Seller shall not have any liability if the alleged infringement is based upon the use or application of the Goods in combination with other Goods and Purchaser shall indemnify Seller there for. Seller disclaims all other

liability for infringement of intellectual property rights and further disclaims any liability for incidental or consequential damages.

9. SECURITY. Seller shall retain and Purchaser hereby grants to Seller a Security interest in all Goods delivered hereunder, and all products and proceeds thereof, until the purchase price has been fully paid. It is agreed that all Goods shall retain their personal character and for purposes hereof shall not be deemed to become a fixture by virtue of being annexed or affixed in any manner to any land, machinery, foundation or building of any sort; and that if Goods are placed on any property subject to mortgage or encumbrance, such Goods shall not be subject to such mortgage or encumbrance. Until fully paid for in cash, the Purchaser shall keep all equipment free and clear of all taxes, liens, and encumbrances of any nature whatsoever or howsoever arising and shall provide and maintain adequate insurance thereon (for the full value thereof as shown by the contract price herein plus all installation costs) against loss or damages caused by fire or other casualty customary insured against (all losses under said policies to be payable to Seller or Purchaser). Upon default in the payment of any part of the purchase price, Seller shall have the right, at its election, to take possession of all Goods and remove the same, without legal process or hindrance, or to enter upon Purchaser's premises and render such Goods unusable, and to retain all payments previously made as compensation for use and wear. Upon demand of Seller, the Purchaser shall execute and deliver to Seller such further documents and other instruments (including, but not limited to, appropriate Uniform Commercial Code Financing Statements and the assent or agreement of any persons having interests in or liens upon the property upon which the Goods are placed) in form satisfactory to Seller, which Seller may reasonably require to secure to Seller the rights conferred upon it under this section. Notwithstanding anything to the contrary herein, the Purchaser hereby irrevocably appoints Seller as its attorney-in-fact, with full authority in the place and stead of the Purchaser, from time to time in the Seller's discretion, to execute any Uniform Commercial Code financing statements deemed necessary or advisable by the Seller to perfect or evidence its interests hereunder.

10. ADDITIONAL TERMS of SALE. If Seller in its judgment at any time, whether before or after acceptance of an order, deems that the continuance of production or delivery on the foregoing terms is not justified, or if the Seller reasonably deems his security to be in jeopardy, he may require full or partial payment in advance.

11. TIME of DELIVERY and INSTALLATION. Seller will use reasonable diligence to meet the schedule dates for shipment, delivery, and installation but cannot guarantee any delivery or completion date. Seller shall not be liable for any loss, damage, expense or charge of any kind resulting from delay in delivery, installation or attainment of operational status of the machinery.

12. GENERAL CONDITIONS. No agent, salesman or other party is authorized to bind Seller by any agreement, warranty, statement, promise or understanding not herein expressed.

The sale of Goods pursuant to this order shall be governed by the laws of the State of Tennessee, without regard to or for the conflict of laws principles thereof.

Any notice which is required or permitted under the terms of this Agreement shall be in writing and delivered to the address of the party set forth in this Agreement. Either party may change address by written notice.

The remedies herein reserved by the parties shall be cumulative and additional to any other or further remedies provided in law or at equity which the parties may possess. In addition to the rights and remedies conferred upon Seller by law, Seller shall not be required to proceed with the performance of any order or contract if Purchaser is in default in the performance of any order or contract with Seller.

Any clerical errors are subject to correction.

No delay or omission by Seller in exercising any right or remedy provided for herein shall constitute a waiver of such right or remedy and shall not be constituted as a bar to or waiver of any such right or remedy on any future occasion.

The waiver, illegality, invalidity or unenforceability of any provision appearing in this Agreement shall not affect the validity of the Agreement as a whole or the validity of any other provisions herein.

This contract shall be binding upon and shall inure to the benefit of the successors and assigns of Purchaser and Seller. Purchaser may not assign or transfer this contract, in whole or in part, except upon the prior written consent of Seller.